

Flue gas analyzer

HODAKATEST HT-1300Z

User manual



HT-1300Z

typeS: O₂,CO,°C

typeA: O₂,CO,NO,°C

typeB: O₂,CO,NO low,°C

typeC: O₂,CO high,°C

typeD: O₂,CO,NO,NO₂,°C

typeE: O₂,NO,NO₂,SO₂,°C

HODAKA
Saving energy

HODAKA CO., LTD.

1-6-17 Takadono Asahiku

Osaka Japan 535-0031

TEL+81-(0)6-6922-5503 FAX +81-(0)6-6922-5895

Email: ht@hodaka-inc.co.jp

URL <https://www.hodaka-inc.co.jp>

ver. 260424

1. Content

1. Content	1
2. Introduction	3
2.1 Flue Gas Analyzer HT-1300Z	3
2.1.1 Function	3
2.1.2 Purpose	3
2.2 Important Instructions regarding the User Manual	4
2.3 Sensor	4
3. Safety Regulations	4
3.1 Safety Instructions	4
4. Device Illustrations	6
4.1 Overview	6
4.2 Connection Port	7
4.3 Keyboard	7
5. Power Supply	8
6. Storage	8
6.1 Operating and Storage Temperature	8
6.2 Long-term Storage without Operation	8
7. Measurement Preparation	8
7.1 Probe Connection	8
8. Operation	9
8.1 Operation – Basic	9
8.1.1 Charging	9
8.1.2 Switch on the Unit	10
8.1.3 Start Measurement	10
8.1.4 Switch off the Unit	12
8.2 Operation – Measurement Menu	13
8.2.1 Measurement Menu	13
8.2.2 Measurement Program Selection	13
8.2.2.1 Program Selection	13
8.2.2.2 CO Cut-off	14
8.2.2.3 Fuel Type Selection	14
8.2.2.4 Fuel Indication Setting	14
8.2.2.5 O ₂ Reference Value Setting	15
8.2.3 Core Flow Search	15
8.2.4 Submenu	15
8.2.4.1 Submenu Item Setting	16
8.2.5 Draft Measurement	16
8.2.5.1 Draft Sensor Zero Setting	16
8.2.6 Save Data	17
8.2.7 View Last Values	17
8.2.8 Pressure Measurement	18
8.2.9 Zero Setting	19

8.3 Operation – Stored Data Menu	20
8.3.1 Stored Data Menu	20
8.3.1.1 View Stored Sites	20
8.3.1.2 Delete Stored Site	21
8.3.1.3 Delete All Sites	21
8.3.1.4 Import Site Data	22
8.3.1.5 Export Stored Data	22
8.3.1.6 Memory Occupation	23
8.4 Operation – Extra Menu	23
8.4.1 Extra Menu	23
8.4.1.1 Device Settings	23
8.4.1.2 Set Time and Date	24
8.4.1.3 Service Menu	25
8.4.1.4 Service	25
8.4.1.5 Default Config	25
8.5 Print Out	26
9. Calculation	27
10. Specification	28
11. Cross-interference	30
12. Condensate Trap	31
13. Message	32
14. Troubleshooting	33
15. Guarantee	33

2. Introduction

2.1 Flue Gas Analyzer HT-1300Z

HT-1300Z has the following functions, and is used for the below purposes:

2.1.1 Function

- Flue gas measurement of O₂, CO, NO, NO₂, SO₂
- Temperature measurement of flue gas
- Pressure measurement
- Differential pressure measurement
- Calculation of efficiency, losses, and etc.
- 4 measurement items / 8 measurement items indication change (gas measurement)
- Data storage (100 data)
- Purging pump for CO sensor protection (option)
- Auto-off function

2.1.2 Purpose





- Combustion control for oil and gas burners
- Maintenance for hot water boilers, steam boilers, and etc.
- Environmental analysis of incinerators
- Temperature control of industrial furnaces.
- Flue gas control and maintenance of gas engines and cogeneration facilities
- Control and measurement for other facilities which related to oil and gas combustion

2.2 Important Instructions regarding the User Manual

This user manual is an important part of the scope of supply and assures not only the correct operation and use of the analyzer, but also the safety of the user and the environment.

Every user is obliged to carefully read the operation manual and to strictly observe all instructions regarding safety.

Several marks are used in this manual. Below are the meaning of each mark.

 DANGER	 WARNING
High risk of decease or injury	Risk of decease or injury
 NOTICE	
Risk of injury or damage to possessions.	Note

2.3 Sensor

Sensor lives are very much influenced by the frequency in use, gas concentrations, and condensate. Generally, the lifetime of an O₂ sensor is approx. 1 to 2 years, and CO / NO / NO₂ sensors are approx. 2 to 3 years. Even if the sensor is not used, it is exposed to the ambient air, so the sensor will gradually be consumed.

3. Safety Regulations

For the safe and correct measurement, the safety instructions below must be followed very carefully.

3.1 Safety Instructions



DANGER

- The analyzer is only to be used with the delivered grip power.
- The analyzer is not to be used in or under water
- The end of the probe is sharp, so please be careful to handle not to damage bodies.

WARNING

- The analyzer is NOT explosion protection. Please avoid using at dangerous areas.
- The gases emitted from the analyzer during measurement may contain toxic substances, therefore, please conduct enough ventilation.
- Moisture, being pumped out of the condensates trap can be slightly acidic. In case of skin contact, IMMEDIATELY clean affected parts of the body! Avoid getting liquid in eyes!
- After measurement, vent the analyzer with ambient air and allow the probe to cool. A hot probe could burn individuals or cause fires nearby flammable materials.
- The metal tube of the probe as well as any other metal/accessories are not to be used as electric conductors.

NOTICE

- The analyzer is not to be placed near or directly exposed to open fire or heat.
- Decomposition or remodeling must not be done.
- The indicated range of temperature of the probe is not to be exceeded, as the probe, temperature sensory mechanism and sensor could be destroyed.
- The analyzer must not be dropped.
- The magnet is used on the rear housing. Therefore, any precision machine should not be settled near the analyzer.
- After measurement, purge the analyzer with fresh air, and remove the moisture in the condensate trap. If the star filter is wet or dirty, please replace it.
- The analyzer must not be stored at high temperature and high humidity.
- The exhalations of alcoholic compounds (e.g. organic solvent, petrol, spirit, varnish, and etc.) may damage the sensors, so please avoid placing and using these compounds near by the analyzer.
- During zero setting, the probe must be taken off from the chimney and be exposed to fresh air.
- Zero setting with flue gas may cause sensor errors.
- Please charge the analyzer every 3 weeks. During long-term storage, the battery may discharge and the sensors might become defective or the stored data might be lost.
- For correct measurements, please ask calibration to HODAKA CS center once a year. (We recommend doing calibration every 6 months)

4. Device Illustrations

4.1 Overview

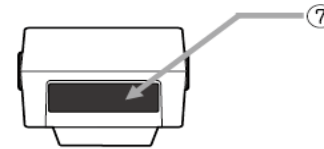
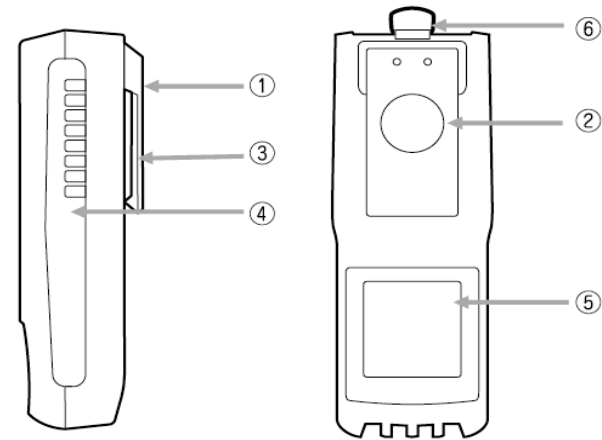

The gases emitted from the analyzer during measurement may contain toxic substances, therefore, please conduct enough ventilation.



Do not see infrared ray.

①	Belt Clip	④	Handle Strip	⑦	IR Interface
②	Magnet	⑤	Battery Cover		
③	Gas Outlet	⑥	Strap Ring		



During measurement, the gas outlet beneath the belt clip must not be covered! Blocking the gas outlet might cause sensor errors.

4.2 Connection Port

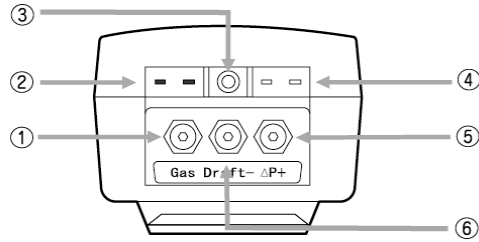

①	Flue gas inlet port	④	Ambient air sensor connection port
②	Combustion air temperature sensor connection port	⑤	Pressure measurement port (Positive pressure measurement port for differential pressure measurement)
③	Battery charger connection port	⑥	Draft pressure measurement port (Negative pressure measurement port for differential pressure measurement)
③	PC interface		

4.3 Keyboard



	Switch ON/OFF key		ESC / Cancel key
	Function key F1		OK key / Confirmation
	Function key F2		Selection key left
	Function key F3		Selection key down
	Printer key		Selection key right
	Submenu key		Selection key up

5. Power Supply

HT-1300Z can be operated by:

- Battery charger (AC100-240V 50/60Hz DC9V 550mA)
- Internal battery (Max. 12 hours of continuous operation (with the back light off))

Danger Use the HT-1300Z only with the power supply Hodaka provide.

6. Storage

6.1 Operating and Storage Temperature

Operating : +0°C ~ +45°C

Storage : -20°C ~ +50°C

Notice Keep the device in a dry place.

6.2 Long-term Storage without Operation

Even the device is powered-off, a small quantity of current is used to keep sensors stable. The battery is also discharged by itself, so please charge every 3 weeks and check the remaining battery. Keep the device with low battery voltage might cause a battery error or a sensor error.

Notice Do not store the HT-1300Z with the battery empty. In case you use HT-1300Z after a long-term storage, firstly discharge the battery completely, and then charge it fully.

7. Measurement Preparation

7.1 Probe Connection

Please connect to each connection port as the picture below.

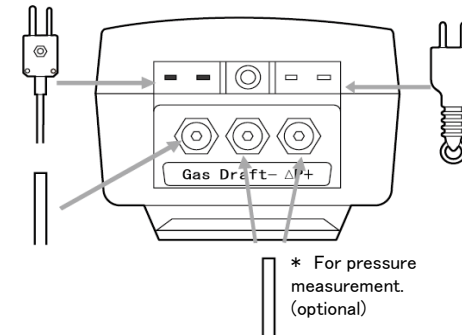

Option *The ambient air temperature is used to calculate values which the temperature is needed such as efficiency, losses, and etc. In case the optional ambient air temperature sensor is not used, the temperature which the flue gas temperature sensor at the end of the probe measures during the zero setting is used as the ambient air temperature

8. Operation

8.1 Operation – Basic

8.1.1 Charging

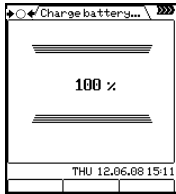

After the battery charger is connected, the indication changes to "Charge battery".
During the battery charger is connected, the charged % is indicated.

It takes approx. 5 hours to charge from 0% to 100%

Date and time

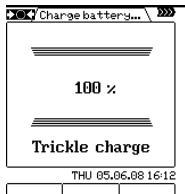

After the battery is fully charged, it will be changed to trickle charge to avoid overcharge.

We recommend using up all battery voltage before charging the battery.

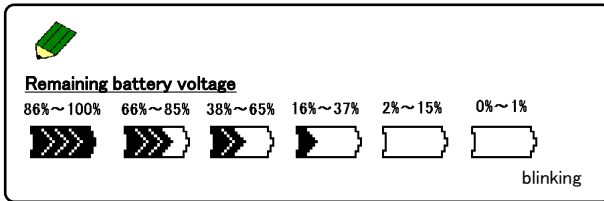

8.1.2 Switch on the Unit

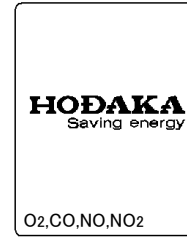

: Switch on the unit.

The mounted sensors are indicated at the bottom of window.

After approx. 5 seconds., the unit automatically goes to the next window.

A message for zero setting will be indicated.

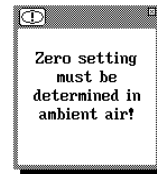

: Move to the next window.
In case [OK key] is not pressed, the unit goes to the next window automatically after approx. 8 seconds.

Notice Zero setting must be conducted in the ambient air. It may be the cause of sensor errors if the probe comes into contact with the flue gas during zero setting.

Zero setting takes approx. 30 seconds.

During the zero setting, the below mark is indicated on the left upper corner of the window.

: Zero setting mark

Once the zero setting is finished, the mark will be disappeared.

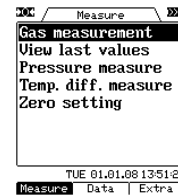

8.1.3 Start Measurement

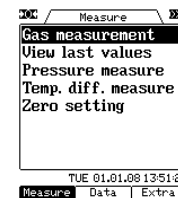

In case the same program is used

: Measurement starts.
In case the same Program No. / Fuel / CO limit / O₂ reference value as the previous time are used, it is possible to move to the measurement window only pressing the F1key.

In case a different program is used

: 8.2.2 Measurement program selection
(When the cursor is on the position of "Gas measurement")

: 8.3.1 Stored data menu

: 8.4.1 Setting menu

Selected measurement program

Fuel and O₂ reference value

Current page

Max. 24 measurement items can be indicated
8 items/page total 3 pages
4 items/page total 6 pages

◀ ▶ : Switch 4 items / 8 items indication.

▲ ▼ : Switch the pages.

(F1) : Start / stop measurement.

(F2) : 8.2.5 Draft Measurement

(F3) : 8.2.6 Save Data

(ESC) : Measurement menu

☰ : 8.2.4 Submenu

🖨️ : Print out

⚠️ During measurement the gas outlet beneath the belt clip must not be covered! Blocking the gas outlet might cause sensor errors.

Measurement Items

Indication	Items	Unit
O ₂	Oxygen	%
CO ₂	Carbon dioxide	%
CO	Carbon monoxide	ppm, mg/m ³ , (mg/kWh, mg/MJ)*1
CO	Carbon monoxide	%
CO/0%	CO reference O2 (O2=0%)	ppm
CO refO ₂	CO reference O2 (O2=?%)	ppm, mg/m ³ , g/m ³
NO	Nitrogen monoxide	ppm, mg/m ³ , (mg/kWh, mg/MJ)*1
NO/0%	NO reference O2 (O2=0%)	ppm
NO refO ₂	NO reference O2 (O2=?%)	ppm, mg/m ³
NOx	Nitrogen oxide	ppm, mg/m ³ , (mg/kWh, mg/MJ)*1
NOx/0%	NOx reference O2 (O2=0%)	ppm
NOx refO ₂	NOx reference O2 (O2=?%)	ppm, mg/m ³
NO ₂	Nitrogen dioxide	ppm
SO ₂	Sulfur dioxide	ppm, mg/m ³ , (mg/kWh, mg/MJ)*1
SO ₂ /0%	SOx reference O2 (O2=0%)	ppm
SO ₂ refO ₂	SOx reference O2 (O2=?%)	ppm, mg/m ³
T.Gas	Combustion gas temperature	°C
T.Air	Ambient air temperature	°C
Losses	Losses	%
Effic.	Efficiency	%
ExAir	Excess air	%
Dew point	Dew point	°C

*1 Please do not use these units as no calculation factor is implemented at present.

8.1.4 Switch off the Unit

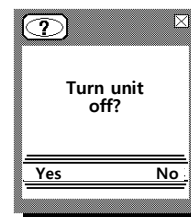

Please take off the probe from the measuring point, and vent the analyzer with the ambient air. Make sure that the values in the measurement window go back to normal values in the ambient air.

It is possible to switch off at all window.

- ⏻ : The window on the left is indicated.
- (F1) : Press [Yes] to turn the unit off.
- (F3) : Press [No] to NOT turn the unit off.

8.2 Operation – Measurement Menu

8.2.1 Measurement Menu

F1: Measurement

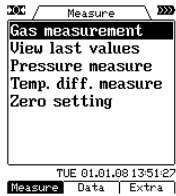

F2: Stored data menu



F3: Extra menu (Settings)



If the instrument is not used for more than 30 minutes in windows other than the measurement window, it will be automatically switched off by "auto-off" function.

8.2.2 Measurement Program Selection

8.2.2.1 Program Selection

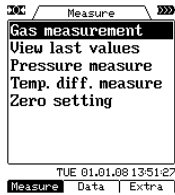

: Move to the measurement program selection.



: Move the cursor up and down, and select one program among "Program 1" ~ "Program 5".

: 8.2.2.2 CO Cut-off

: 8.2.2.3 Fuel Selection

It is possible to store the settings of 8.2.2.2 CO Limit, 8.2.2.3 Fuel Selection, 8.2.2.4 Fuel Indication Setting, and 8.2.4.1 Submenu Item Setting.

8.2.2.2 CO Cut-off

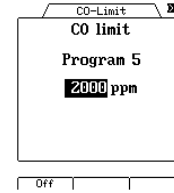

: Change the CO threshold value
For the range of 300 ppm ~ 3000 ppm, it can be set every 100 ppm.
For the range of 3000 ppm ~ 10000 ppm, it can be set every 500 ppm.

In case the CO purging pump is installed:
If the CO value exceeds the threshold, the purging pump starts working and sucks the ambient air to protect the CO sensor.

In case the CO purging pump is not installed:
If CO value exceeds the threshold, the CO indication becomes "----".

Purge: CO purging pump is in operation.
Limit over: CO value exceeds the threshold value.
Range over: CO value exceeds the measurement range.
----: CO sensor has an error.

In case the unit does not have a CO sensor, the CO purging pump is not mounted, too.

: CO measurement Off

: Back to 8.2.2.1 Program Selection

8.2.2.3 Fuel Type Selection

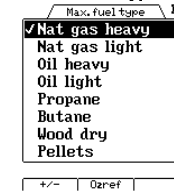

: Move the cursor and select a fuel type.

: Confirm it to move to the measurement window.

: 8.2.2.4 Fuel Indication Setting

In case "Test gas" is selected, the calculated items, such as CO2, will not be calculated.

8.2.2.4 Fuel Indication Setting

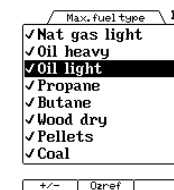

Only fuels with a check mark will be indicated on the fuel selected window.

: Move the cursor up and down.

: Check / Un-check the fuels.

: 8.2.2.5 O₂ Reference Value Setting

: 8.2.2.3 Fuel Type Selection

Fuel Type
13A→6C→LPG→Kerosine→Light
Oil→Heavy A→Heavy C→Pellets

8.2.2.5 O₂ Reference Value Setting

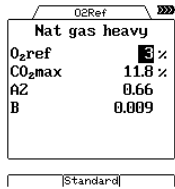

◀ ▶ : Change the O₂ reference value.

F2 : Turn back to the default values.
Default value:
 Test gas=0%, other items =3%

OK ESC : 8.2.2.4 Fuel Indication Setting

"CO₂ max" of the left window indicates CO₂ max value of fuel.

Please ignore "A2" and "B".

8.2.3 Core Flow Search

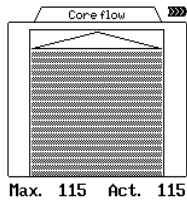

Max. 115: The highest temperature so far

Act. 115: The current temperature which is measured by temperature sensor.

The core flow search can be switched off on the device settings. (8.4.1.1 Device Settings)

Insert the probe slowly to flue gas, and the temperature sensor finds where is the highest temperature in the flue.

Once the probe is away from where the highest temperature, the gauge on the left window goes down. Take the probe back to where the temperature is highest and fix it at the position with the cone of the probe.

OK : After fixing the probe, move to the measurement window.

The core flow search is the function to find the highest temperature in the combustible gas. In case it is not necessary, it can be off on 8.4.1.1 Device Settings.

8.2.4 Submenu

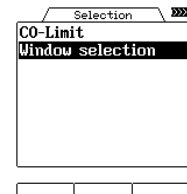

▲ ▼ : Move the cursor up and down

OK : 8.2.2.2 CO Cut-off
 (When the cursor position is on "CO-Limit")

: 8.2.4.1 Submenu item setting
 (When the cursor position is on "Window selection")

ESC : Move to the measurement window

8.2.4.1 Submenu Item Setting

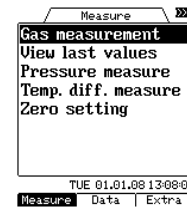

▲ ▼ : Move the cursor up and down.

◀ ▶ : Change the items.

OK : Stop item selection and move to the measurement window.

ESC : 8.2.1 Draft Sensor Zero Setting

8.2.5 Draft Measurement



F1 : Fix the draft measurement value.

F3 : 8.2.5.1 Draft Sensor Zero Setting

ESC : Move to the measurement window.

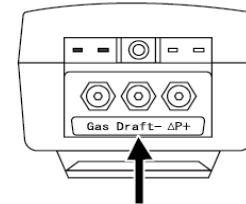

For draft measurement, please connect the pressure measurement hose to "Draft -" port.

8.2.5.1 Draft Sensor Zero Setting

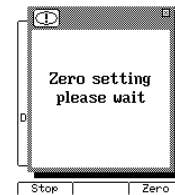

OK : Move to the next window.

Notice Zero setting of the draft sensor must be conducted in the ambient air. If zero setting are done with the draft sensor pressurized, the value will become abnormal.

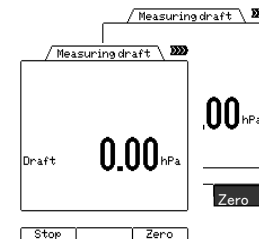

During zero setting of the draft sensor, the color of the button "Zero" [F3 key] on the window is inverted.

After the zero setting is completed, "Zero" [F3 key] turns back to normal.

8.2.6 Save Data

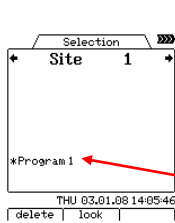

: Scroll sites.
Stored No. is shown as the left window indicates. You can overwrite the data, but the original data will be deleted.



: Confirm the site to store.

Program No.

Date and time

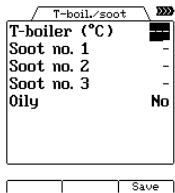

In case "Yes" is selected for Boiler temp.*/ Smoke no.? on 8.4.1.1 Device settings, the left window is indicated.
"Oily" is indicated only in case "Yes" is selected for Smoke no.?



: Change the value, and select yes/no.



: Move the cursor.



: Save data.

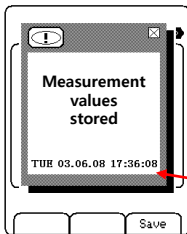

Date and time



Soot no. and Oily: Please fill out the sampling data which is taken by smoke tester. (Oily is the adherent unburned fuel on the filter paper of smoke tester.)

8.2.7 View Last Values

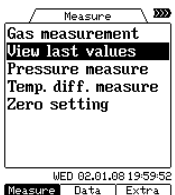

After the measurement is stopped by pressing [ESC key], it is possible to see the last time value.



: Move the cursor and select "View last values".



: Confirm it to move to the next window.



Once the instrument is turned off, the last values will be deleted.

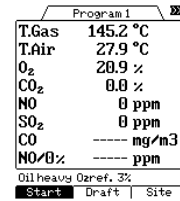

: Switch 4 pages / 8 pages indication.



: Switch the pages.



: Start a measurement.



: 8.2.5 Draft Measurement



: 8.2.6 Save Data



: Move to the measurement window.



: 8.4.4 Submenu



: Print out

8.2.8 Pressure Measurement

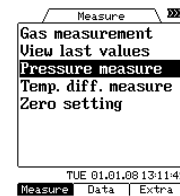

Max. 4 points of pressure can be measured. Connect a hose to Δ P+ connection port. For differential pressure measurement, connect a second hose to Draft - connection port.

*For differential pressure measurement, an optional probe is needed.



: Move the cursor and select "Pressure Measurement".



: Confirm it to move to the next window.

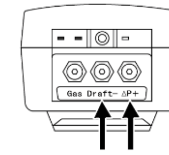

Positive pressure
Negative pressure



: Move the cursor



: Confirm the value which is pointed by the cursor.



: Reset all pressure values 1 to 4 to 0.00hPa



: Zero setting of the pressure sensor
Move to the next window.



: Print out



: Stop the pressure measurement, and the unit goes to the measurement window.



: Stop the zero setting of pressure sensor.
Back to the above window.



Zero setting of the pressure sensor must be determined in ambient air.

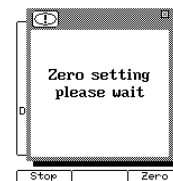
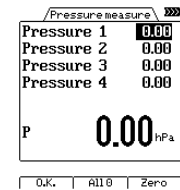

8.2.9 Zero Setting

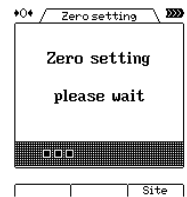
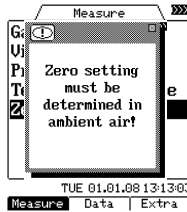
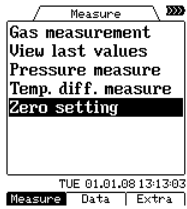

▲ ▼ : Move the cursor and select "Zero setting".

OK : Confirm it to move to the next window.

OK : Move to the next window.
In case [OK key] is not pressed, it automatically moves to the next window after approx. 8 seconds.

Notice Zero setting must be determined in ambient air.

Zero setting takes approx. 30 seconds.

During the zero setting, the below mark is indicated on the left upper corner of the window.

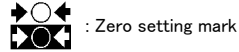

ESC : Move to the measurement menu window, so it is possible to change settings and to seeing stored data during the zero setting.

8.3 Operation – Stored Data Menu

8.3.1 Stored Data Menu

8.3.1.1 View Stored Sites



▲ ▼ : Move the cursor and select "View stored sites".

OK : Confirm it to move to the next window.

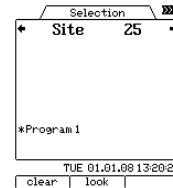

◀ ▶ : Select a stored site.

F1 : Move to 8.3.2 Delete Stored Sites.

F2 : Move to the next window.

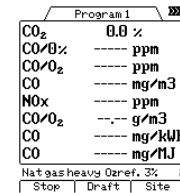

◀ ▶ : Switch 4 lines / 8 lines indication.

▲ ▼ : Switch the pages.

F1 F3

F2 : Move to the next window.

Print : Print out

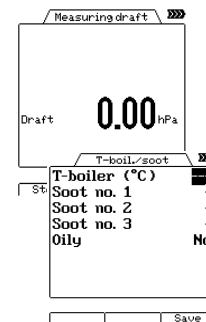

F2 : Move to the next window.
(Boiler temperature / Soot no.)

The window on the left is shown only if "Yes" is selected for the settings of Boiler temp? / Smoke no.? of 8.4.1.1 Device Settings.

"Oily" is indicated if "Yes" is selected for Smoke no. ?

F2 : Move to the selection window of stored sites.

8.3.1.2 Delete Stored Site



- : Move the cursor and select "Site data base".
- : Confirm it to move to the next window.



- : Select a site to be deleted.
- : Move to the next window.

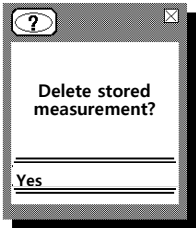

- : Press [Yes] to delete a site.
- : Press [No] to NOT delete a site.

It moves back to the previous window after the deletion is completed or [NO] is pressed in the left window.

8.3.1.3 Delete All Sites



- : Move the cursor and select "Delete sites".
- : Confirm it to move to the next window.

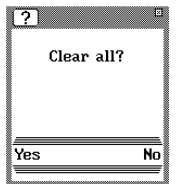

- : Press [Yes] to delete all sites.
- : Press [No] to NOT delete all sites.

It moves back to the previous window after the deletion is completed or [NO] is pressed in the left window.

8.3.1.4 Import Site Data

Please do not use this function.

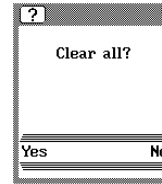

If "Import site data" is opened by mistake, the window on the left will be shown. Press [F3 key] to go back to the stored data menu.

8.3.1.5 Export Stored Data



- : Move the cursor and select "Export stored data".
- : Confirm it to move to the next window.

When you export stored data, please refer to the manual of Online View, too.

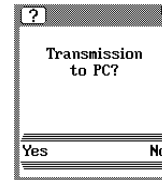

- : Press [Yes] to export the data.
- : Press [No] to NOT export the data.



The message on the left is indicated during the data transmission. After the transmission is completed, it goes back to the stored data menu.

8.3.1.6 Memory Occupation



- ▲ ▼ : Move the cursor and select "Memory occupation".
- OK : Confirm it to move to the next window.

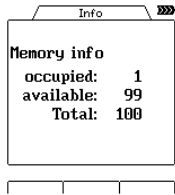

The current memory occupation is shown as in the left window.

- OK ESC : Back to the stored data menu above.

8.4 Operation – Extra Menu

8.4.1 Extra Menu

8.4.1.1 Device Settings



- ▲ ▼ : Move the cursor and select "Device settings".
- OK : Confirm it to move to the next window.

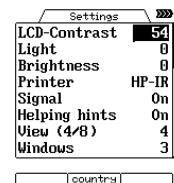

- ▲ ▼ : Move the cursor.
- ◀ ▶ : Change the values.
- F2 : Move to the next window.
- OK ESC : Back to the extra menu above.

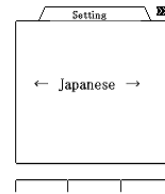

- ◀ ▶ : Switch between Japanese and English.
- OK ESC : Back to the above window.

Setting items	Range	Description
LCD-Contrast	-14 ~ 7	Display contrast can be adjusted.
Back light	0 ~ 30 minutes	Lighting time of back light of the display
Brightness	1 ~ 3	Brightness of the back light
Printer	HP-IR	This item is not changeable.
Signal	On / Off	On / Off for the sound when pressing a key
Window (4/8)	4 / 8	4 / 8 items indication on the window
Page	1 / 2 / 3	The number of the windows can be selected.
Boiler temp. ?	Yes / No	Select "Yes" if the input is necessary.
Smoke no. ?	Yes / No	Select "Yes" if the input is necessary.
Measurement point	On / Off	Activate / Deactivate the core flow search
COM	RS232 / Blue.	Select RS232 cable / Bluetooth depending on which one is used for the measurement software.
NOx ratio	1.00 ~ 2.50	Set NO ₂ ratio (if NO ₂ sensor is not mounted)

8.4.1.2 Set Time and Date



- ▲ ▼ : Move the cursor and select "Set time and date".
- OK : Confirm it to move to the next window.

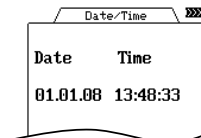

- OK : The cursor is indicated.

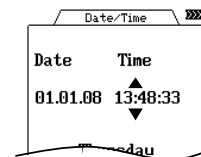

- ▲ ▼ : Change the numbers.
- ◀ ▶ : Move the cursor.
- ESC : Back to the above window.

8.4.1.3 Service Menu

Please do not use this function.

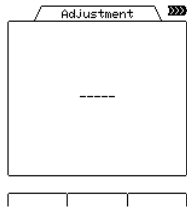

If "Service" is opened by mistake, the window on the left will be shown. Press [ESC key] 5 times to escape.

8.4.1.4 Service

Please do not use this function.

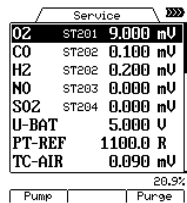

If "Service" is opened by mistake, the window on the left will be shown. Press [ESC key] to escape.

8.4.1.5 Default Config

Please do not use this function.



If "Service" is opened by mistake, the window on the left will be shown. Press [F3 key] to escape.

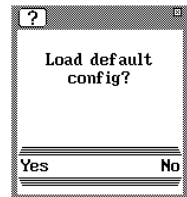

8.5 Print Out

For print out, an optional infrared printer (HT-1610) is needed.

Warning Do not see infrared ray.

Gas Measurement

date.month.year: 03.07.2018

hour:minute:second: 08:38:54

13A 15.8 12.2%

Program1

O2	20.9%
CO2	0.03%
NO	0.0ppm
NO2	0.1ppm
NO	0.1ppm

DewPnt. -----°C

Draft 0.00hPa

T-boiler(°C) 84

Soot no.1 0

Soot no.2 0

Soot no.3 1

Oily No

T-boiler (°C)

Soot no. 1, 2, 3

Oily: (Yes), (No)

Measure HT-1300Z

SN 100012

03.07.2018 08:38:54

Program1

O2	20.9%
CO2	0.03%
NO	0.0ppm
NO2	0.1ppm
NO	0.1ppm

DewPnt. -----°C

Draft 0.00hPa

T-boiler(°C) 84

Soot no.1 0

Soot no.2 0

Soot no.3 1

Oily No

Pressure Measurement

Measure HT-1300Z

SN 100012

03.07.2018 08:38:54

Pressure Measurement

hPa

Diff.Pressure 1 -0.13

Diff.Pressure 2 0.65

Diff.Pressure 3 1.78

Diff.Pressure 4 -0.03

P 24.38hPa

O₂ref.%

CO₂ max. value

<Measurement items>

- T.Gas (°C)
- O₂ (%)
- CO₂ (%)
- CO (ppm)
- CO (%)
- NO (ppm)
- NO₂ (ppm)
- SO₂ (ppm)
- NOx (ppm)
- T.Air (°C)
- Exc.Air
- Losses (%)
- Effic. (%)
- CO/0% (ppm)
- COrefO₂ (ppm)
- CO (mg/m³)
- NO/0% (ppm)
- NOrefO₂ (ppm)
- NO (mg/m³)
- NOx/0% (ppm)
- NOxrefO₂ (ppm)
- NOx(NO₂) (mg/m³)
- SO₂/0% (ppm)
- SO₂ refO₂ (ppm)
- SO₂ (mg/m³)
- Dew Point (°C)
- Draft (hPa)

9. Calculation

$$\text{Excess Air } (\lambda) = \frac{20.9(\%)}{20.9(\%) - \text{O}_2(\%) \text{ in flue gas}}$$

$$\text{CO}_2 (\%) = \frac{\text{CO}_2\text{Max} \times (20.9 - \text{O}_2(\%) \text{ in flue gas})}{20.9(\%)}$$

$$\text{Losses} = \frac{(\text{GO} + (\lambda - 1) \times \text{AO}) \times 0.33 \times (\text{Combustable gas } (^\circ\text{C}) - (\text{Ambient temp. } ^\circ\text{C})) \times 100}{\text{Calp (kcal/Nm}^3 \text{ or kg)}}$$

$$\text{Efficiency} = 100 - \text{losses}$$

$$\text{CO/O}_2 (\text{ppm}) = \frac{20.9(\%) - \text{O}_2 \text{ reference}\%}{20.9(\%) - \text{O}_2(\%) \text{ in flue gas}} \times \text{CO (ppm)}$$

$$\text{CO (mg/m}^3) = \text{CO (ppm)} \times 1.249$$

$$\text{CO/O}_2 (\text{mg/m}^3) = \frac{20.9(\%) - \text{O}_2 \text{ reference}\%}{20.9(\%) - \text{O}_2(\%) \text{ in flue gas}} \times \text{CO (mg/m}^3)$$

$$\text{NO/O}_2 (\text{ppm}) = \frac{20.9(\%) - \text{O}_2 \text{ reference}\%}{20.9(\%) - \text{O}_2(\%) \text{ in flue gas}} \times \text{NO (ppm)}$$

$$\text{NO (mg/m}^3) = \text{NO (ppm)} \times 1.339$$

$$\text{NO/O}_2 (\text{mg/m}^3) = \frac{20.9(\%) - \text{O}_2 \text{ reference}\%}{20.9(\%) - \text{O}_2(\%) \text{ in flue gas}} \times \text{NO (mg/m}^3)$$

$$\text{NOx (ppm)} = \text{NO (ppm)} \times K (\text{manually adjustable}) \quad \text{NO}_2 : \text{Non mounted}$$

$$\text{NOx (ppm)} = \text{NO (ppm)} + \text{NO}_2 (\text{ppm}) \quad \text{NO}_2 : \text{Mounted}$$

$$\text{NOx/O}_2 (\text{ppm}) = \frac{20.9(\%) - \text{O}_2 \text{ reference}\%}{20.9(\%) - \text{O}_2(\%) \text{ in flue gas}} \times \text{NOx (ppm)}$$

$$\text{NOx (mg/m}^3) = \text{NOx (ppm)} \times 2.053$$

$$\text{NOx/O}_2 (\text{mg/m}^3) = \frac{20.9(\%) - \text{O}_2 \text{ reference}\%}{20.9(\%) - \text{O}_2(\%) \text{ in flue gas}} \times \text{NOx (mg/m}^3)$$

$$\text{SO}_2/\text{O}_2 (\text{ppm}) = \frac{20.9(\%) - \text{O}_2 \text{ reference}\%}{20.9(\%) - \text{O}_2(\%) \text{ in flue gas}} \times \text{SO}_2 (\text{mg/m}^3)$$

$$\text{SO}_2 (\text{mg/m}^3) = \text{SO}_2 (\text{ppm}) \times 2.859 \quad \times \text{SO}_2 (\text{ppm/m}^3)$$

$$\text{SO}_2/\text{O}_2 (\text{mg/m}^3) = \frac{20.9(\%) - \text{O}_2 \text{ reference}\%}{20.9(\%) - \text{O}_2(\%) \text{ in flue gas}} \times \text{SO}_2 (\text{mg/m}^3)$$

$$\text{Dew Point} = \frac{4077.9}{16.7241 - \ln \left(1.1 + \frac{100}{1 + \frac{f_w}{\text{CO}_2}} \right)} - 236.67$$

Fuel Data

Test gas	GO Nm ³	AO Nm ³	Calp kcal/Nm ³ or kcal/kg	CO ₂ Max	f _w
13A	0.0	0.0	0	0.0	0
6C	11.79	10.71	9714	12.1	57
LPG	4.89	4.08	4050	13.1	77
Kerosene	25.9	23.9	22350	13.8	77
Light oil	12.15	11.37	10570	15.1	111
Heavy A	11.9	11.15	10280	15.4	111
Heavy C	11.37	10.68	10160	15.8	111
Pellet	10.88	10.25	9750	16	111
	4.63	4.63	4200	20.3	0

*The fuel data might slightly differ depending on locations, therefore, some errors may occur to the calculated values.

*When measuring sulfur-rich flue gas, the actual dew point might be different from the calculated dew point.

GO: Theoretical flue gas volume, AO: Theoretical air volume, Calp: Low calorific value, CO₂max: CO₂ Max. value of each fuel, f_w: Humidity index

10. Specification

HODAKA TEST TM HT-1300Z			
Measurement	O ₂	Measurement Range	0 ~ 20.9 vol%
		Accuracy	±0.2 vol%
CO (H ₂ Compensation)*1	CO (H ₂ Compensation)*1	Resolution	0.1 vol%
		Response Time	within 20 sec.
		Measurement Range	0 ~ 2000 ppm (max. overload 10000 ppm)
		Accuracy	±10 ppm or ±5% reading (0 ~ 2000 ppm) ²
CO very high	CO very high	Resolution	±10% reading (2001 ~ 10000 ppm)
		Response Time	1 ppm
		Measurement Range	within 40 sec. (0~2000 ppm) within 60 sec. (2001~10000 ppm)
		Accuracy	0.00 ~ 4.00% (max. overload 10.00%)
NO	NO	Resolution	±0.02% or ±5% reading (0.00 ~ 2.00%) ²
		Response Time	±10% reading (2.01 ~ 10.00%)
		Measurement Range	0.01%
		Accuracy	within 60 sec. (0.00~2.00%) within 100 sec. (2.01~10.00%)
NO low	NO low	Measurement Range	0 ~ 1000 ppm (max. overload 3000 ppm)
		Accuracy	±5 ppm or ±5% reading (0 ~ 1000 ppm) ²
		Resolution	±10% reading (1001 ~ 3000 ppm)
		Response Time	1 ppm
NO ₂	NO ₂	Measurement Range	within 40 sec. (0~1000 ppm) within 60 sec. (1001~3000 ppm)
		Accuracy	0 ~ 300 ppm
		Resolution	±2 ppm (0.0 ~ 39.9 ppm)
		Response Time	±5% reading (40.0 ~ 300 ppm)
SO ₂	SO ₂	Resolution	0.1 ppm (0.0 ~ 99.9 ppm) 1 ppm (100 ~ 300 ppm)
		Response Time	within 40 sec.
		Measurement Range	0 ~ 200 ppm (max. overload 500 ppm)
		Accuracy	±10 ppm (0 ~ 200 ppm)
Pressure	Pressure	Resolution	±10% reading (201 ~ 500 ppm)
		Response Time	1 ppm (0.1 ppm) ³
		Measurement Range	within 60 sec. (0~200 ppm) within 100 sec. (201~500 ppm)
		Accuracy	0 ~ 2000 ppm (max. overload 4000 ppm)
Combustion air temp.	Combustion air temp.	Resolution	±10 ppm or ±5% reading (0 ~ 2000 ppm) ²
		Response Time	±10% reading (2001 ~ 4000 ppm)
		Measurement Range	1 ppm
		Accuracy	within 60 sec. (0~2000 ppm) within 100 sec. (2001~4000 ppm)
Ambient air temp.	Ambient air temp.	Resolution	±100 hPa
		Response Time	F.S. ±2%
		Measurement Range	0.01 hPa
		Accuracy	0 ~ 650°C or 0 ~ 1100°C (depending on the probe)
Calculated Value **	Calculated Value **	Resolution	0 ~ 100°C: ±2°C
		Response Time	100°C ~: ±2% reading
		Measurement Range	0.1°C (0 ~ 999.9°C) 1°C (1000 ~ 1100°C)
		Accuracy	0 ~ 100°C
mg/m ³	mg/m ³	Resolution	±2°C
		Response Time	0.1°C
		Measurement Range	0 ~ 2000 ppm (max. overload 4000 ppm)
		Accuracy	±10 ppm or ±5% reading (0 ~ 2000 ppm) ²
		Resolution	1 ppm
		Response Time	within 60 sec. (0~2000 ppm) within 100 sec. (2001~4000 ppm)
		Measurement Range	±100 hPa
Accuracy	F.S. ±2%		
Resolution	0.01 hPa		
Calculated Value **	Calculated Value **	Measurement Range	0 ~ 650°C or 0 ~ 1100°C (depending on the probe)
		Accuracy	0 ~ 100°C: ±2°C
		Response Time	100°C ~: ±2% reading
		Resolution	0.1°C (0 ~ 999.9°C) 1°C (1000 ~ 1100°C)
mg/m ³	mg/m ³	Measurement Range	0 ~ 100°C
		Accuracy	±2°C
		Resolution	0.1°C
		Measurement Range	0 ~ 2000 ppm (max. overload 4000 ppm)
		Accuracy	±10 ppm or ±5% reading (0 ~ 2000 ppm) ²
		Resolution	1 ppm
		Response Time	within 60 sec. (0~2000 ppm) within 100 sec. (2001~4000 ppm)
mg/m ³	mg/m ³	Measurement Range	±100 hPa
		Accuracy	F.S. ±2%
		Resolution	0.01 hPa
		Measurement Range	0 ~ 2000 ppm (max. overload 4000 ppm)
		Accuracy	±10 ppm or ±5% reading (0 ~ 2000 ppm) ²
		Resolution	1 ppm
		Response Time	within 60 sec. (0~2000 ppm) within 100 sec. (2001~4000 ppm)
mg/m ³	mg/m ³	Measurement Range	0 ~ 2000 ppm (max. overload 4000 ppm)
		Accuracy	±10 ppm or ±5% reading (0 ~ 2000 ppm) ²
		Resolution	1 ppm
		Response Time	within 60 sec. (0~2000 ppm) within 100 sec. (2001~4000 ppm)
		Measurement Range	0 ~ 2000 ppm (max. overload 4000 ppm)
		Accuracy	±10 ppm or ±5% reading (0 ~ 2000 ppm) ²
		Resolution	1 ppm
Response Time	within 60 sec. (0~2000 ppm) within 100 sec. (2001~4000 ppm)		
mg/m ³	mg/m ³	Measurement Range	0 ~ 2000 ppm (max. overload 4000 ppm)
		Accuracy	±10 ppm or ±5% reading (0 ~ 2000 ppm) ²
		Resolution	1 ppm
		Response Time	within 60 sec. (0~2000 ppm) within 100 sec. (2001~4000 ppm)
		Measurement Range	0 ~ 2000 ppm (max. overload 4000 ppm)
		Accuracy	±10 ppm or ±5% reading (0 ~ 2000 ppm) ²
		Resolution	1 ppm
Response Time	within 60 sec. (0~2000 ppm) within 100 sec. (2001~4000 ppm)		
mg/m ³	mg/m ³	Measurement Range	0 ~ 2000 ppm (max. overload 4000 ppm)
		Accuracy	±10 ppm or ±5% reading (0 ~ 2000 ppm) ²
		Resolution	1 ppm
		Response Time	within 60 sec. (0~2000 ppm) within 100 sec. (2001~4000 ppm)
		Measurement Range	0 ~ 2000 ppm (max. overload 4000 ppm)
		Accuracy	±10 ppm or ±5% reading (0 ~ 2000 ppm) ²
		Resolution	1 ppm
Response Time	within 60 sec. (0~2000 ppm) within 100 sec. (2001~4000 ppm)		
mg/m ³	mg/m ³	Measurement Range	0 ~ 2000 ppm (max. overload 4000 ppm)
		Accuracy	±10 ppm or ±5% reading (0 ~ 2000 ppm) ²
		Resolution	1 ppm
		Response Time	within 60 sec. (0~2000 ppm) within 100 sec. (2001~4000 ppm)
		Measurement Range	0 ~ 2000 ppm (max. overload 4000 ppm)
		Accuracy	±10 ppm or ±5% reading (0 ~ 2000 ppm) ²
		Resolution	1 ppm
Response Time	within 60 sec. (0~2000 ppm) within 100 sec. (2001~4000 ppm)		
mg/m ³	mg/m ³	Measurement Range	0 ~ 2000 ppm (max. overload 4000 ppm)
		Accuracy	±10 ppm or ±5% reading (0 ~ 2000 ppm) ²
		Resolution	1 ppm
		Response Time	within 60 sec. (0~2000 ppm) within 100 sec. (2001~4000 ppm)
		Measurement Range	0 ~ 2000 ppm (max. overload 4000 ppm)
		Accuracy	±10 ppm or ±5% reading (0 ~ 2000 ppm) ²
		Resolution	1 ppm
Response Time	within 60 sec. (0~2000 ppm) within 100 sec. (2001~4000 ppm)		
mg/m ³	mg/m ³	Measurement Range	0 ~ 2000 ppm (max. overload 4000 ppm)
		Accuracy	±10 ppm or ±5% reading (0 ~ 2000 ppm) ²
		Resolution	1 ppm
		Response Time	within 60 sec. (0~2000 ppm) within 100 sec. (2001~4000 ppm)
		Measurement Range	0 ~ 2000 ppm (max. overload 4000 ppm)
		Accuracy	±10 ppm or ±5% reading (0 ~ 2000 ppm) ²
		Resolution	1 ppm
Response Time	within 60 sec. (0~2000 ppm) within 100 sec. (2001~4000 ppm)		
mg/m ³	mg/m ³	Measurement Range	0 ~ 2000 ppm (max. overload 4000 ppm)
		Accuracy	±10 ppm or ±5% reading (0 ~ 2000 ppm) ²
		Resolution	1 ppm
		Response Time	within 60 sec. (0~2000 ppm) within 100 sec. (2001~4000 ppm)
		Measurement Range	0 ~ 2000 ppm (max. overload 4000 ppm)
		Accuracy	±10 ppm or ±5% reading (0 ~ 2000 ppm) ²
		Resolution	1 ppm
Response Time	within 60 sec. (0~2000 ppm) within 100 sec. (2001~4000 ppm)		
mg/m ³	mg/m ³	Measurement Range	0 ~ 2000 ppm (max. overload 4000 ppm)
		Accuracy	±10 ppm or ±5% reading (0 ~ 2000 ppm) ²
		Resolution	1 ppm
		Response Time	within 60 sec. (0~2000 ppm) within 100 sec. (2001~4000 ppm)
		Measurement Range	0 ~ 2000 ppm (max. overload 4000 ppm)
		Accuracy	±10 ppm or ±5% reading (0 ~ 2000 ppm) ²
		Resolution	1 ppm
Response Time	within 60 sec. (0~2000 ppm) within 100 sec. (2001~4000 ppm)		
mg/m ³	mg/m ³	Measurement Range	0 ~ 2000 ppm (max. overload 4000 ppm)
		Accuracy	±10 ppm or ±5% reading (0 ~ 2000 ppm) ²
		Resolution	1 ppm
		Response Time	within 60 sec. (0~2000 ppm) within 100 sec. (2001~4000 ppm)
		Measurement Range	0 ~ 2000 ppm (max. overload 4000 ppm)
		Accuracy	±10 ppm or ±5% reading (0 ~ 2000 ppm) ²
		Resolution	1 ppm
Response Time	within 60 sec. (0~2000 ppm) within 100 sec. (2001~4000 ppm)		
mg/m ³	mg/m ³	Measurement Range	0 ~ 2000 ppm (max. overload 4000 ppm)
		Accuracy	±10 ppm or ±5% reading (0 ~ 2000 ppm) ²
		Resolution	1 ppm
		Response Time	within 60 sec. (0~2000 ppm) within 100 sec. (2001~4000 ppm)
		Measurement Range	0 ~ 2000 ppm (max. overload 4000 ppm)
		Accuracy	±10 ppm or ±5% reading (0 ~ 2000 ppm) ²
		Resolution	1 ppm
Response Time	within 60 sec. (0~2000 ppm) within 100 sec. (2001~4000 ppm)		
mg/m ³	mg/m ³	Measurement Range	0 ~ 2000 ppm (max. overload 4000 ppm)
		Accuracy	±10 ppm or ±5% reading (0 ~ 2000 ppm) ²
		Resolution	1 ppm
		Response Time	within 60 sec. (0~2000 ppm) within 100 sec. (2001~4000 ppm)
		Measurement Range	0 ~ 2000 ppm (max. overload 4000 ppm)
		Accuracy	±10 ppm or ±5% reading (0 ~ 2000 ppm) ²
		Resolution	1 ppm
Response Time	within 60 sec. (0~2000 ppm) within 100 sec. (2001~4000 ppm)		
mg/m ³	mg/m ³	Measurement Range	0 ~ 2000 ppm (max. overload 4000 ppm)
		Accuracy	±10 ppm or ±5% reading (0 ~ 2000 ppm) ²
		Resolution	1 ppm
		Response Time	within 60 sec. (0~2000 ppm) within 100 sec. (2001~4000 ppm)
		Measurement Range	0 ~ 2000 ppm (max. overload 4000 ppm)
		Accuracy	±10 ppm or ±5% reading (0 ~ 2000 ppm) ²
		Resolution	1 ppm
Response Time	within 60 sec. (0~2000 ppm) within 100 sec. (2001~4000 ppm)		
mg/m ³	mg/m ³	Measurement Range	0 ~ 2000 ppm (max. overload 4000 ppm)
		Accuracy	±10 ppm or ±5% reading (0 ~ 2000 ppm) ²
		Resolution	1 ppm
		Response Time	within 60 sec. (0~2000 ppm) within 100 sec. (2001~4000 ppm)
		Measurement Range	0 ~ 2000 ppm (max. overload 4000 ppm)
		Accuracy	±10 ppm or ±5% reading (0 ~ 2000 ppm) ²
		Resolution	1 ppm
Response Time	within 60 sec. (0~2000 ppm) within 100 sec. (2001~4000 ppm)		
mg/m ³	mg/m ³	Measurement Range	0 ~ 2000 ppm (max. overload 4000 ppm)
		Accuracy	±10 ppm or ±5% reading (0 ~ 2000 ppm) ²
		Resolution	1 ppm
		Response Time	within 60 sec. (0~2000 ppm) within 100 sec. (2001~4000 ppm)
		Measurement Range	0 ~ 2000 ppm (max. overload 4000 ppm)
		Accuracy	±10 ppm or ±5% reading (0 ~ 2000 ppm) ²
		Resolution	1 ppm
Response Time	within 60 sec. (0~2000 ppm) within 100 sec. (2001~4000 ppm)		
mg/m ³	mg/m ³	Measurement Range	0 ~ 2000 ppm (max. overload 4000 ppm)
		Accuracy	±10 ppm or ±5% reading (0 ~ 2000 ppm) ²
		Resolution	1 ppm
		Response Time	within 60 sec. (0~2000 ppm) within 100 sec. (2001~4000 ppm)
		Measurement Range	0 ~ 2000 ppm (max. overload 4000 ppm)
		Accuracy	±10 ppm or ±5% reading (0 ~ 2000 ppm) ²
		Resolution	1 ppm
Response Time	within 60 sec. (0~2000 ppm) within 100 sec. (2001~4000 ppm)		
mg/m ³	mg/m ³	Measurement Range	0 ~ 2000 ppm (max. overload 4000 ppm)
		Accuracy	±10 ppm or ±5% reading (0 ~ 2000 ppm) ²
		Resolution	1 ppm
		Response Time	within 60 sec. (0~2000 ppm) within 100 sec. (2001~4000 ppm)
		Measurement Range	0 ~ 2000 ppm (max. overload 4000 ppm)
		Accuracy	±10 ppm or ±5% reading (0 ~ 2000 ppm) ²
		Resolution	1 ppm
Response Time	within 60 sec. (0~2000 ppm) within 100 sec. (2001~4000 ppm)		
mg/m ³	mg/m ³	Measurement Range	0 ~ 2000 ppm (max. overload 4000 ppm)
		Accuracy	±10 ppm or ±5% reading (0 ~ 2000 ppm) ²
		Resolution	1 ppm
		Response Time	within 60 sec. (0~2000 ppm) within 100 sec. (2001~4000 ppm)
		Measurement Range	0 ~ 2000 ppm (max. overload 4000 ppm)
		Accuracy	±10 ppm or ±5% reading (0 ~ 2000 ppm) ²
		Resolution	1 ppm
Response Time	within 60 sec. (0~2000 ppm) within 100 sec. (2001~4000 ppm)		
mg/m ³	mg/m ³	Measurement Range	0 ~ 2000 ppm (max. overload 4000 ppm)
		Accuracy	±10 ppm or ±5% reading (0 ~ 2000 ppm) ²
		Resolution	1 ppm
		Response Time	within 60 sec. (0~2000 ppm) within 100 sec. (2001~4000 ppm)
		Measurement Range	0 ~ 2000 ppm (max. overload 4000 ppm)
		Accuracy	±10 ppm or ±5% reading (0 ~ 2000 ppm) ²
		Resolution	1 ppm
Response Time	within 60 sec. (0~2000 ppm) within 100 sec. (2001~4000 ppm)		
mg/m ³	mg/m ³	Measurement Range	0 ~ 2000 ppm (max. overload 4000 ppm)
		Accuracy	±10 ppm or ±5% reading (0 ~ 2000 ppm) ²
		Resolution	1 ppm
		Response Time	within 60 sec. (0~2000 ppm) within 100 sec. (2001~4000 ppm)
		Measurement Range	0 ~ 2000 ppm (max. overload 4000 ppm)
		Accuracy	±10 ppm or ±5% reading (0 ~ 2000 ppm) ²
		Resolution	1 ppm
Response Time	within 60 sec. (0~2000 ppm) within 100 sec. (2001~4000 ppm)		
mg/m ³	mg/m ³	Measurement Range	0 ~ 2000 ppm (max. overload 4000 ppm)
		Accuracy	±10 ppm or ±5% reading (0 ~ 2000 ppm) ²
		Resolution	1 ppm
		Response Time	within 60 sec. (0~2000 ppm) within 100 sec. (2001~4000 ppm)
		Measurement Range	0 ~ 2000 ppm (max. overload 4000 ppm)
		Accuracy	±10 ppm or ±5% reading (0 ~ 2000 ppm) ²
		Resolution	1 ppm
Response Time	within 60 sec. (0~2000 ppm) within 100 sec. (2001~4000 ppm)		
mg/m ³	mg/m ³ </		

Fuel	13A, 6C, LPG, Kerosene, Light oil, Heavy A, Heavy C, Pellet			
Sensor	O ₂	Galvanic		
	CO (CO very high)	Electrochemical		
	NO (NO low)	Electrochemical		
	NO ₂	Electrochemical		
	SO ₂	Electrochemical		
	Combustible Gas Temp.	K Thermo-couple		
	Ambient Air Temp.	K Thermo-couple		
Main Unit	Pressure	Piezoresistive semiconductor		
	Temperature	Operating Temperature: +0°C ~ +45°C Storage Temperature: -20°C ~ +50°C		
	Display	Dot Matrix 8 items ⇄ 4 items		
	Dimension	(W × H × D) 80 x 210 x 60 mm		
	Weight	Approx. 680 g		
	Power Supply	External: Line power (AC100-240V 50/60Hz DC9V 550mA) Internal: NiMH batteries (Max. 12 hours continuous operation)		
	Standard Equipment	Built-in	Pump, Interface for PC (RS232), CO purge pump ^{*5} Data logger (100 data), Interface for printer	
Accessory		Adapter, Probe (with sampling hose), Condensate trap, Pressure measurement hose, Soft case, Star filter		
Item		Art. No.	Specification	
Sampling Probe (with T-gas Sensor)	HT-1009	L= 180 mm φ 5 mm ~650°C Hose 1500 mm		
Sampling Probe (with T-gas Sensor)	HT-1011	L= 300 mm φ 6 mm ~650°C Hose 2700 mm		
Sampling Probe (with T-gas Sensor)	HT-1012 ^{*6}	L= 300 mm φ 6 mm ~650°C Hose 2700 mm		
Option	Probe Handle	HT-7201SS	Sampling hose 2700 mm	
		HT-7202SS ^{*6}	Sampling hose 2700 mm	
	Probe Tube (with T-gas Sensor)	HT-7230	L= 300 mm φ 6 mm ~650°C Hose 2700 mm	
		HT-7235	L= 500 mm φ 6 mm ~650°C Hose 2700 mm	
		HT-7232	L= 750 mm φ 6 mm ~650°C Hose 2700 mm	
		HT-7233	L= 750 mm φ 8 mm ~1100°C Hose 2700 mm	
	CO Purging Pump	HT-2321	CO sensor protection	
	Ambient Temperature Sensor	HT-2305	0 ~ 100°C	
	Temperature Probe	K Thermo-couple	HT-1252a	φ 1.5 × 130L, 0 ~ 950°C, For air / liquid
			HT-1253a	φ 3 × 130L, 0 ~ 400°C, For air / liquid / food / sharpened tip
			HT-1254a	130L, 0 ~ 400°C, For surface / rift / air / liquid
			HT-1255a	φ 4 × 130L, 0 ~ 650°C, For surface / air / liquid
			HT-1256a	0 ~ 450°C, Magnetic probe for surface
			HT-1257a	0 ~ 180°C, Pliers probe for plate / tube
	Pressure Sensor Unit	HT-2303	Pressure, Differential pressure, Draft pressure, 2 x Hose (1 m)	
	Draft Probe	HT-1050	L= 180 mm, φ 5 mm, Hose 3000 mm	
	Attache Case	HT-2315	Dimension: 340 mm × 490 mm × 125 mm Weight: 3 kg	
Measurement Software	HT-2074	Online View (Windows7/8.1/10) (with RS232 cable)		
Measurement Software	HT-2084	Online View (Windows7/8.1/10) (with RS232 cable, USB cable)		
Bluetooth Module ^{*7}	HT-2333	For the measurement software		
Infrared Printer	HT-1610	1 x Printer roll paper, 4 x AA Battery		
Roll Paper for Infrared Printer	HT-1636	5 Rolls		

*1 The compensation for the measured value in case the measured gas including H₂

*2 A higher value is applied as accuracy.

*3 In case the NO low sensor is mounted, the resolution is 0.1 ppm in the measurement range of 0.0 ppm to 99.9 ppm.

*4 The fuel data might slightly differ depending on locations, therefore, some errors may occur to the calculated values.

*5 For HT-1300Z type S and devices without the CO sensor: CO purging pump is not mounted.

*6 For CO high / NO₂ / SO₂ measurement

*7 Measurement software (HT-2074) is needed.

Specifications may be changed without notice.

11. Cross-interference

Art. No.	Sensor	Cross-interference Gas							
		CO	NO	NO ₂	SO ₂	H ₂	H ₂ S	HCL	H ₂ C
HT1607	O ₂	0	0	0	0	0	0	0	no data
HT1608	CO (H ₂) ^{*1}	-	0	0	0	0	no data	5%	no data
HT2044	NO	0	-	< 10%	0	0	0	< 5%	no data
HT2040	NO ₂	< -1%	< 1%	-	≒ -3%	< -1%	≒ -25%	< -1%	no data
HT3040	SO ₂	≒ 3.5%	< -5%	< -150%	-	< 2%	< 2%	no data	no data
HT2325	CO very high	-	0	0	0	< 60%	0	0	< 10%

*1 The sensor is with H₂ compensation, the H₂ concentration up to 2000 ppm is internally compensated.

* In case the sensor which measures the cross-interference gas is installed, the cross-interference is compensated based on the measured data. However, it may not fully be compensated if the concentration of the cross-interference gas is extremely high.

12. Condensate Trap

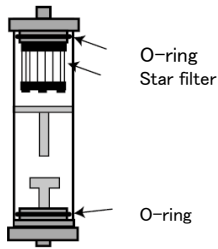

Exchanging the star filter



Turn the joint and take the star filter out.

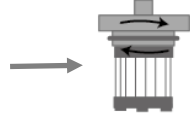

Loose the star filter as the direction of the arrows above.



Star filter is a consumption part. Once the color turns gray, please exchange it.

-Using compressed air as first-aid cleaning-



Direction of air

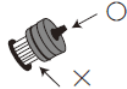

Removing the moisture

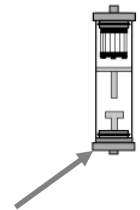

Take this cap off.



Turn the joint to open, and remove the moisture.



Please make sure that the O-ring is properly put in the slit of the joint. Bad fitting may cause leakage.

Wrong example:
O-ring is twisted.

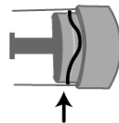

13. Message

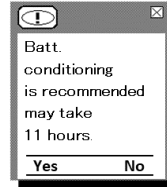

The message on the left is indicated every 60 days.
No: Usual battery charge will start.
Yes: Battery conditioning will start. (It may take max. 11 hours)



Notice

Before starting the battery conditioning, let the instrument work and discharge the battery.



The battery conditioning is recommended to keep the life of the battery as long as possible.

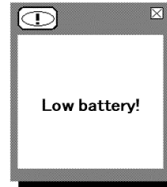

Condition : The voltage of the battery is too low.
Reason 1 : The battery is not charged enough.
Solution : Charge the battery.
Reason 2 : The contact of the battery charger is poor.
Solution : Connect the battery charger again.
Reason 3 : The wire of the battery charger is broken.
Solution : Exchange the battery charger.
Please ask HODAKA CO., LTD. for a new one.



Condition : The inside temperature of the unit is too high.
Reason 1 : The unit is stored in a hot place.
Solution : Move the unit to a cooler place.
Reason 2 : Temperature sensor error
Solution : Please ask HODAKA CO., LTD. for repair.



Condition : The inside temperature of the unit is too low.
Reason 1 : The unit is stored in a cold place.
Solution : Move the unit to a warmer place.
Reason 2 : Temperature sensor error
Solution : Please ask HODAKA CO., LTD. for repair.

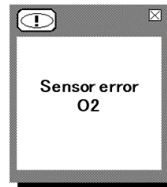

Condition : Sensor error
Reason 1 : The end of the life of each sensor
Solution : Please ask HODAKA CO., LTD. for repair.
Reason 2 : The unit has been stored without operation for a long time.
Solution : Charge the battery and restart the unit.
Reason 3 : Zero setting was done in flue gas.
Solution : Conduct zero setting again in the ambient air.

* The left window is an example of O₂ sensor error.

14. Troubleshooting

Behaviour	Possible Cause	Solution
The device cannot be charged. The charging window is not shown.	Is the battery charger correctly connected?	Check the contact of the battery charger.
	Is the battery charger the one Hodaka supplied (HT2301)?	Exchange the battery charger.
The device cannot be operated even though it is turned on.	The battery is not charged enough.	Charge the battery with the battery charger.
The flue gas temperature is not indicated.	Is the temp. connector correctly connected?	Check the contact of the temp. connector.
The ambient air temperature is not indicated.	Is the ambient air temp. sensor correctly connected?	Check the contact of the ambient air temp. sensor.
The indicated concentration is wrong.	There is a leakage from the probe.	Check if the screw is loosened. Tighten it if loose.
	There is a hole on the sampling hose.	Cut the perforated part if it enables to use the hose.
	The gas leaks from the condensate trap (due to degradation of o-ring, breakage of the pipe or etc.)	Return the device to HODAKA CO., LTD.
Sensor error	Was the zero setting conducted in the fresh air with the probe taken off from the flue?	Conduct the zero setting in the fresh air. If it was conducted in the flue gas, repeat the process several times to remove gases from sensors.
	The device was left for a long time without operation.	Charge the battery fully and start the device up again.
	The end of the life of sensors	Return the device to HODAKA CO., LTD.
The data cannot be printed.	Is the printer turned on?	Turn on the printer.
	Is there any obstacle between the device and the printer?	Remove the obstacle. Wipe the infrared interface of the device with a dry cloth.
	Are the printer and the device placed within the correct distance and angle?	Refer to the user manual of the infrared printer.
	Is the contrast of the printer	Refer to the user manual of the infrared
The device cannot be communicated with Online View.	Is the communication cable correctly connected?	Check the contact of the communication cable.
	Is the communication cable the one Hodaka supplied?	Exchange the communication cable.
	Is the device in the measurement window?	Turn on the device and move to the measurement window.
Other behaviours		Contact HODAKA CO., LTD.

15. Guarantee

Guarantee: During guarantee period, if your instrument breaks down despite the correct usage based on this user manual, we will repair it free of charge. In case you have any trouble, please fill the calibration and repair request form and send it together with your instrument to HODAKA CO., LTD. HODAKA CO., LTD. will not bear the international transport costs.

HODAKA CO., LTD. shall not be liable for any loss or damage whatever arising from content errors or any mis-use of this instrument.

HODAKA CO., LTD.
1-6-17 Takadono, Asahiku, Osaka, 535-0031, Japan
TEL: +81-(0)6-6922-5503
FAX: +81-(0)6-6922-5895

Traceability certification can be issued by HODAKA. (Additional costs will be required.)